



Fitting Instructions

TOWBAR R32A
For RANGE ROVER 2002-

MATERIALS

A	1	Cross Bar with European facing to 94/20/EC A50-1
B	1	Coupling Packer
D	1	Left hand Sidearm
E	1	Right hand Sidearm
F	2	15mm Spacer Blocks
G	4	M8 x 30 x 1.25 pitch Bolts, Nuts and Lock Washers
H	4	M16 x 50 x 2.0 pitch Bolts, 2 Nuts and Lock Washers
J	2	M10 x 30 x 1.5 pitch Bolts, Nuts, Flat Washers and Lock Washers
CB	2	M16 x 50 x 2.0 pitch Coupling Bolts, Nuts, Lock Washers

FITTING

1. Remove bumper (4 nuts at holes (Y) against rear panel and clips along wheel arches) detach the exhaust hanger brackets from the bumper side support arms, discard bumper side supports (retain fasteners at X & Y).
2. Loosely attach Sidearms (D) and (E) to existing holes at (X) – **firstly ensuring the endplates of Side Brackets (D) & (E) are adequately sealed against the rear panel to prevent water ingress through the end of the chassis rails and holes (Y)**, using original bolts (X) and (Y) and Spacer Blocks (F).
3. Loosely attach Cross Bar (A) to Sidearms (D) and (E) using bolts (H).
4. On vehicles where the exhaust mounting brackets were located at the forward-most bolts (X) refit to the corner hole in Sidearms (D) and (E) using bolts (J). On all other vehicles remount exhaust brackets using fasteners and holes (G).
5. Refit bumper and **fully tighten all bolts**.

Note: This towbar must be used with either a Witter Towball (part number Z11) or Class A50-1 or A50-X towball dimensionally Conforming to A50-1 with a 'D' and 'S' value greater than or equal to that of the towbar.

Please refer to the vehicle specification for the trailer weight and nose limits, which **must be observed**.

Recommended torque settings: M8 - 27Nm, M10 - 53 Nm, M12 - 95 Nm, M14 - 150 Nm, M16 - 214 Nm

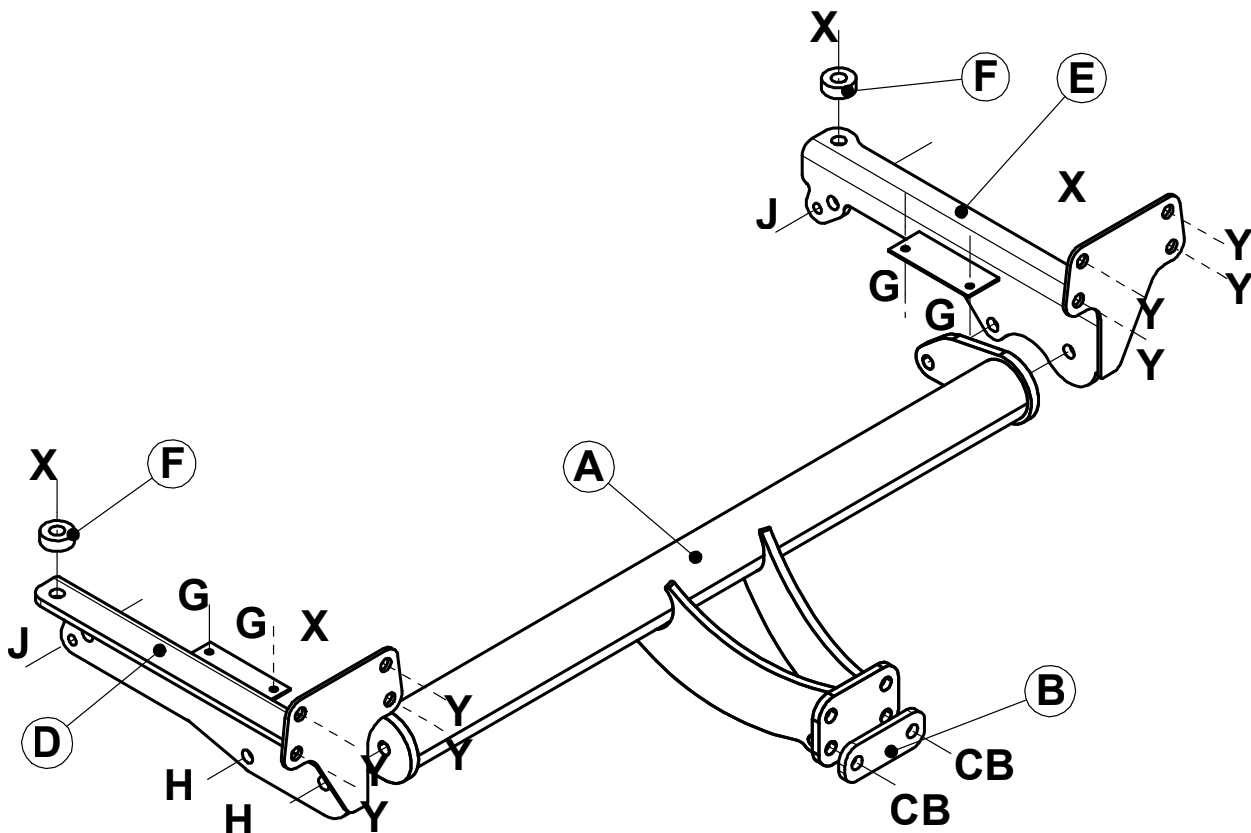

W0001R32A-FIT\$020811240000