



Fitting Instructions

TOWBAR RN56
For RENAULT SCENIC
(1996-)

MATERIALS

A	1	Crossbar Mainframe with European facing to 94/20/EC A50-1
C1	1	Left Hand Sidearm
C2	1	Right Hand Sidearm
D1	2	Spreader Plates
E	4	M12 x 1.75 x 35mm Bolts, Nuts (3), Lock Washers and Flat Washers (25mm O.D)
F	2	M8 x 1.25 x 25mm Bolts, Lock Washers, Flat Washers (25mm O.D) "Cage" Nuts and "Bayonet" Nuts
G	2	M10 x 1.5 x 35mm Bolts, Nuts, Lock Washers and 4 Flat Washers (20mm O.D.)
H	1	M10 x 1.5 x 110mm Bolt, Lock Washer and Flat Washer (40mm O.D.)
J	1	M10 x 1.5 x 100mm Bolt, Lock Washer and Flat Washer (40mm O.D.)
K	2	Bushes (17mm x 54mm Long)
CB	2	M16 x 50mm Coupling Bolts, Nuts and Lock Washers

FITTING

1. Insert Bushes (K) into outer faces of forward chassis mounts. Loosely attach Sidearm (C1) to left side using Bolt (H) with Flat Washer (40mm O.D), and Sidearm (C2) to right using Bolt (J) with Flat Washer (40mm O.D).
2. Identify the 4 "**Key Holes**" (2 each side) in the rear crossmember. Note: The upper 2 holes at (F) are covered by plastic bungs or tape and are heavily coated with mastic. Remove the plastic bungs (or tape) from the upper two and insert either the Cage Nuts or Bayonet Nuts (F) depending on the shape of the holes (see diagram 1 below). Loosely attach Spreader Plates (D1) to these Nuts using Bolts (F) with Flat Washers (25mm O.D).
3. Offer up Crossbar (A) and loosely attach to plates (D1) using Bolts (G) with Flat Washers (20mm O.D) **sandwiching the rear crossmember between the two**, and to Sidearms (C1 and C2) using Bolts (E) with Flat Washers (25mm O.D).
4. Finally, **Tighten all Bolts**.

Note: This towbar must be used with either a Witter Towball (part number Z1) or Class A50-1 or A50-X towball dimensionally conforming to A50-1 with a 'D' and 'S' value greater than or equal to that of the towbar.

Please refer to the vehicle specification for the trailer weight and nose limits, which **must be observed**.

Recommended torque settings: M8 - 27Nm, M10 - 53 Nm, M12 - 95 Nm , M14 - 150 Nm, M16 - 214 Nm

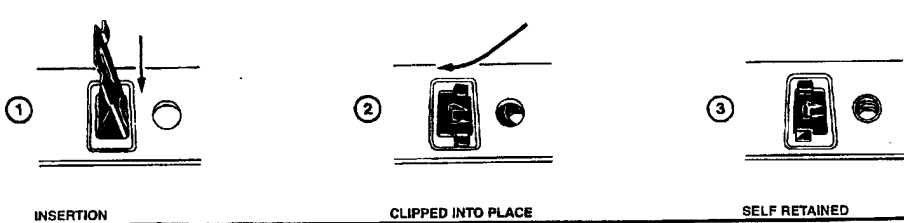

DIAGRAM 2 - INSERTION OF CAGE NUTS

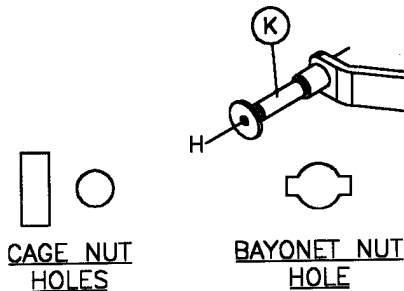
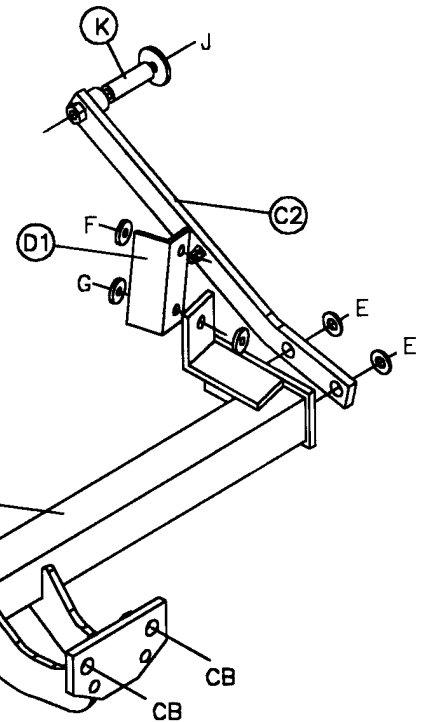

DIAGRAM 1