



Fitting Instructions

TOWBAR SK11A
for SKODA FABIA (March 2000 -)
VW POLO (2002 -)
SEAT IBIZA (2002 -)

MATERIALS

A	1	Tubular Crossbar with European facing to 94/20/EC – A50-1
D	4	M10 x 35 x 1.5mm Bolts, Lock Washers and Large Flat Washers (40mm O.D.)
E	1	Left Hand Side Arm
F	1	Right Hand Side Arm
G	4	M12x35x1.75mm Bolts, Nuts and Lock Washers
CB	2	M16x50x2.0mm Coupling Bolts, Nuts and Lock Washers

FITTING

1. Remove bumper (1 torq screw under lower edge of bumper on each side, 4 torq screws around each wheel arch, 2 torque screws behind each light (remove lights). Remove steel bumper beam (3 M8 nuts each side).
2. Uncover holes in chassis rails for Bolts (D). These are covered with tape and / or mastic. Insert Side Arm (E) into left chassis rail and Side Arm (F) into right chassis rail. Attach using 2 Bolts (D) each side.
3. Attach Crossbar (A) to Side Arms (E) and (F) using Bolts (G). Ensuring Side Arms and Crossbar are level, **Tighten all Bolts.**
4. Cut bumper as shown. Place a protective cover over Crossbar neck. Refit bumper, ensuring lower edge of bumper fits underneath two tags located on underside of vehicle.

NOTES: This towbar must be used with either a Witter Towball (part number Z1) or Class A50-1 or A50-X towball dimensionally conforming to A50-1 with a 'D' and 'S' value greater than or equal to that of the towbar.

Please refer to vehicle specification for trailer weight and nose load limits, which **must be observed.**

Recommended torque settings: M10 - 53 Nm, M12 - 95 Nm, M16 - 214 Nm

ESTATE BUMPER CUT

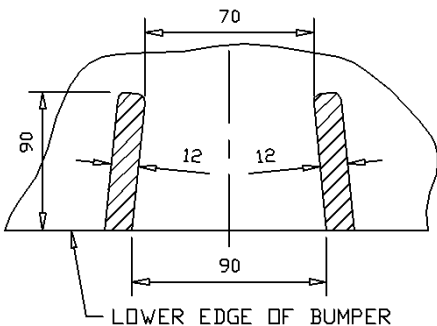

HATCH BUMPER CUT

